

AE89 Heavy Duty Slide -Push-Open

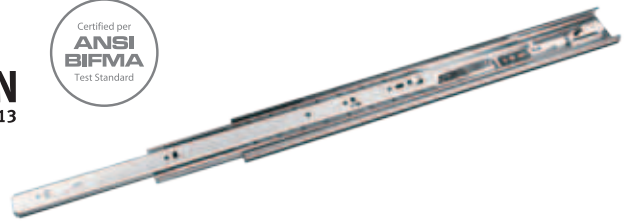

3

Push-Open Ball Bearing Slides

Specifications

- **Length:** 300mm to 700mm (12" to 28")
- **Profile:** 54mm x 12.7mm
- **Travel:** Full Extension
- **Side Space:** 12.7mm (+0.5mm-0mm)
- **Height:** 54mm (2.13")
- **Max. Loading:** 68 kg (150 lb)/pair
- **Mount:** Side Mount
- **Disconnect:** Lever Disconnect
- **Finish:** Clear Zinc or Black
- **Material:** Cold Rolled Steel
- **Packing:** Unit Packed in 5 pairs/carton
Bulk Packed in
10 pcs/carton for cabinet member
100 pcs/carton for drawer member

Features

- Push-Open, Handle-Free
- Dual design allows for traditional pull-open preventing damages caused by improper installation and usage
- Ultra smooth with high rigidity and stability design
- 50,000 life cycles guaranteed under proper installation and normal usage

Applications

- Wide Lateral File Drawers, Large Storage Drawers and Toolbox

Dimension Specifications

mm (inch)

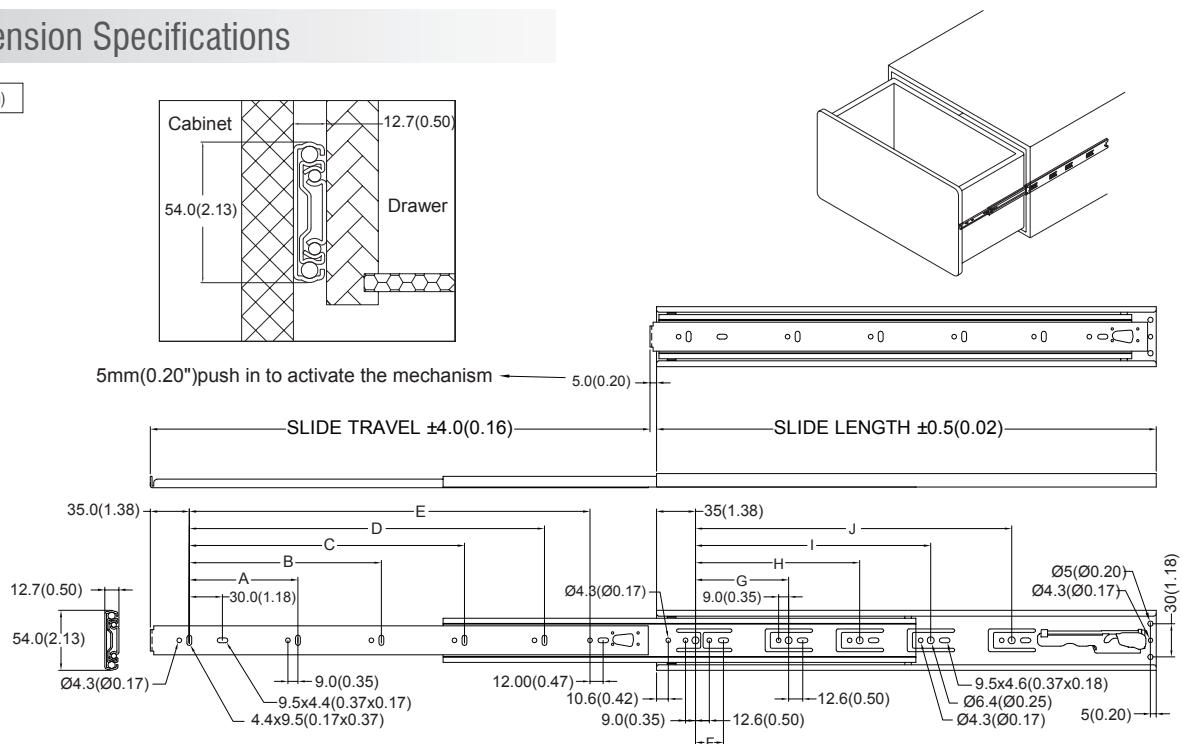

Note: Holes other than those shown may be in the slide member at King Slide's option and may change without notice.



Item No.	Slide Length mm (inch)	Slide Travel mm (inch)	Loading Capacity kg (lb) / pair	HOLES POSITION mm (inch)									
				A	B	C	D	E	F	G	H	I	J
AE89-300	300.0 (11.81)	300.0 (11.81)	54.5 (120.0)	96.0(3.78)	—	—	—	211.0 (8.31)	25.3 (1.00)	—	—	—	128.0 (5.04)
AE89-350	350.0 (13.78)	350.0 (13.78)	54.5 (120.0)	128.0(5.04)	—	—	—	261.0 (10.28)	25.3 (1.00)	128.0 (5.04)	—	—	192.0 (7.56)
AE89-400	400.0 (15.75)	400.0 (15.75)	63.6 (140.0)	128.0(5.04)	—	—	—	311.0 (12.24)	—	128.0 (5.04)	—	—	224.0 (8.82)
AE89-450	450.0 (17.72)	450.0 (17.72)	68.1 (150.0)	128.0(5.04)	352.0 (13.86)	—	—	361.0 (14.21)	25.3 (1.00)	160.0 (6.30)	—	—	288.0 (11.34)
AE89-500	500.0 (19.69)	500.0 (19.69)	68.1 (150.0)	128.0(5.04)	192.0 (7.56)	320.0 (12.60)	—	411.0 (16.18)	25.3 (1.00)	224.0 (8.82)	—	—	320.0 (12.60)
AE89-550	550.0 (21.65)	550.0 (21.65)	68.1 (150.0)	128.0(5.04)	224.0 (8.82)	384.0 (15.12)	—	461.0 (18.14)	25.3 (1.00)	224.0 (8.82)	—	—	384.0 (15.12)
AE89-600	600.0 (23.62)	600.0 (23.62)	68.1 (150.0)	128.0(5.04)	224.0 (8.82)	416.0 (16.38)	—	511.0 (20.12)	25.3 (1.00)	224.0 (8.82)	352.0 (13.86)	—	448.0 (17.64)
AE89-650	650.0 (25.59)	650.0 (25.59)	68.1 (150.0)	128.0(5.04)	224.0 (8.82)	416.0 (16.38)	544.0 (21.42)	561.0 (22.09)	25.3 (1.00)	128.0 (5.04)	352.0 (13.86)	—	480.0 (18.90)
AE89-700	700.0 (27.56)	700.0 (27.56)	68.1 (150.0)	128.0(5.04)	224.0 (8.82)	416.0 (16.38)	544.0 (21.42)	611.0 (24.06)	25.3 (1.00)	128.0 (5.04)	352.0 (13.86)	448.0 (17.64)	544.0 (21.42)

Features

- Push-Open, Handle-Free
- Dual design allows for traditional pull open preventing damages caused by improper installation and usage
- Ultra smooth with high rigidity and stability design

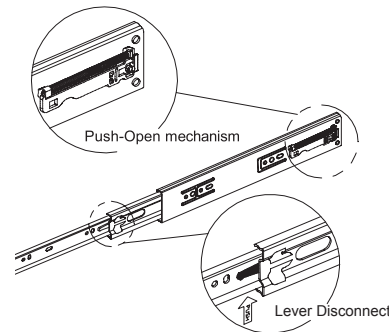

Installation Instruction

1. Press the lever disconnect to separate slide members. (Fig.1)
 2. Install the cabinet members as indicated in Fig2. Make sure both cabinet members are vertically and horizontally parallel.
 3. Install the drawer members as indicated in Fig3. Make sure both drawer members are vertically and horizontally parallel.
 4. Insert drawer members into cabinet members as indicated in Fig4. and push the drawer until it is closed.
- *If sound damper is to be used, a distance of 5mm must be reserved for push-open actuation.
- *The center of front panel is suggested as the best push-open point

Fig. 1

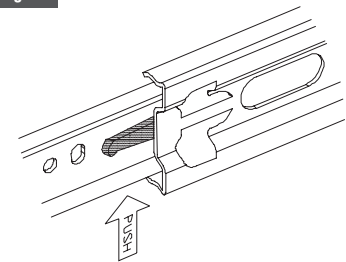

Fig. 2 Lateral Side

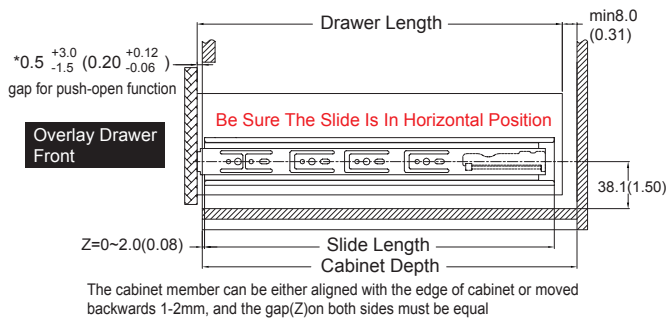

Fig. 3

Drawer member working drawing

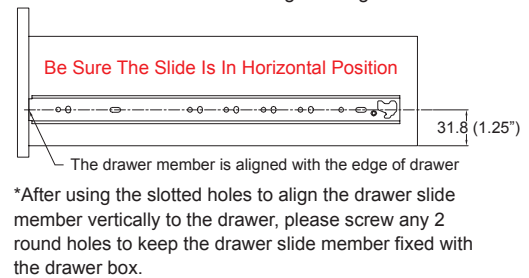

Fig. 4

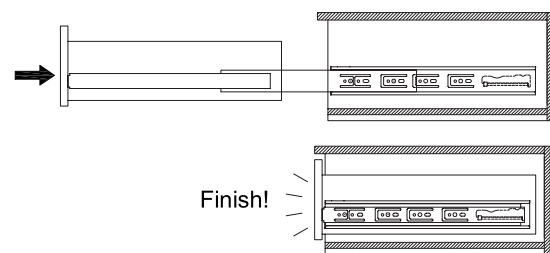

Fig. 5

WARNING

When install the drawer into the cabinet, please make sure the drawer member insert to the ball retainer completely. (Fig.5)

